

电动工具系列



XTEAM[®]
BRUSHLESS SYSTEM

电动工具无刷电机

POWER TOOLS SERIES

ELECTRIC TOOLS BRUSHLESS MOTOR

X-TEAM电动工具系列无刷电机

X-TEAM BL1625无刷电机

应用范围： 基站

MODEL	VOLTAGE		NO LOAD		AT MAXIMUM EFFICIENCY					STALL			
	OPERATING RANGE	NOMINAL	SPEED rpm	CURRENT A	SPEED rpm	CURRENT A	TORQUE g-cm	TORQUE N-m	OUTPUT W	EFF %	CURRENT A	TORQUE g-cm	TORQUE N-m
BL2430B-9V6.2K3W-C1Y0P	9.0-16.0	9.0V CONSTANT	6150	0.12	4990	0.48	52.6	5.20	2.70	64	2.0	280	27.5
BL2430B-32V13.5K8W-B1X0N	9.0-34.0	32.0V CONSTANT	13500	0.10	10930	0.60	123.0	12.10	13.80	72	2.8	660	67.4

馬達的出軸長度及性能參數，EMC 對策可依客人要求做調整，詳情可詢問相關業務人員。
Please inquire your sales representative for output, performance and EMC solution.

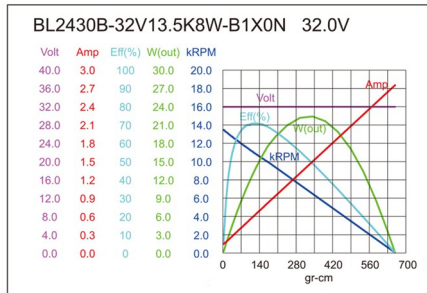
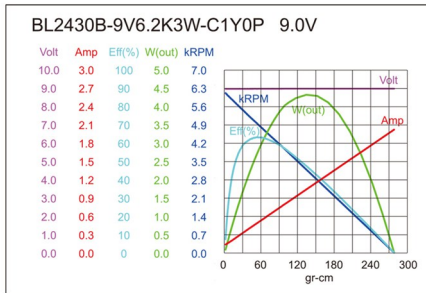
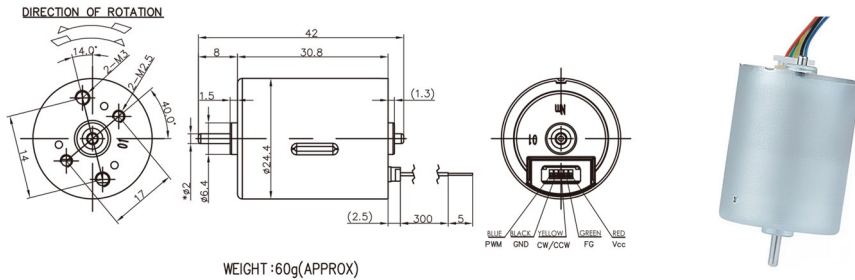

X-TEAM BL2414 无刷电机

应用范围： 智能家居、吸尘器、风扇

MODEL	VOLTAGE		NO LOAD		AT MAXIMUM EFFICIENCY				STALL				
	OPERATING RANGE	NOMINAL	SPEED rpm	CURRENT A	SPEED rpm	CURRENT A	TORQUE g-cm	TORQUE N-m	OUTPUT W	EFF %	CURRENT A	TORQUE g-cm	TORQUE N-m
BL24E14B-12V16.8K9W-C0Y0P	10.0-16.0	12.0V CONSTANT	17200	0.4	12359	1.62	86.9	8.52	11.04	58	4.92	351.5	34.45
BL24E14B-12V23.7K20W-C0Y0P	10.0-16.0	12.0V CONSTANT	24000	0.48	20200	2.05	62.2	6.09	12.90	59	8.90	375.1	36.76

馬達的輸出長度及性能參數，EMC 對策可依客人要求做調整，詳情可詢問相關業務人員。
Please inquire your sales representative for output, performance and EMC solution.

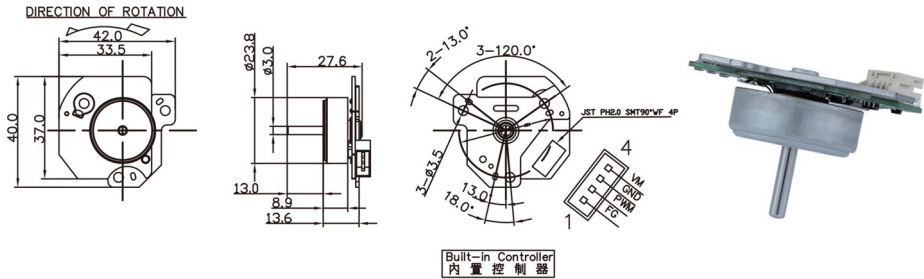

WEIGHT :20g(APPROX)

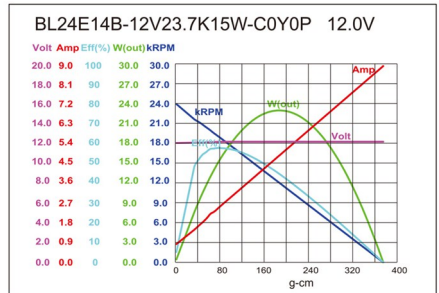
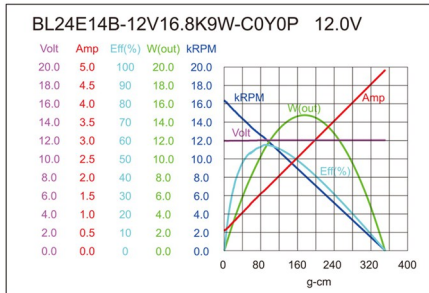

ELECTRIC TOOLS BRUSHLESS MOTOR

X-TEAM电动工具系列无刷电机

X-TEAM BL2430无刷电机

应用范围： 电动工具、5G天线、智能家居、电动吸尘器

MODEL	VOLTAGE		NO LOAD		AT MAXIMUM EFFICIENCY				STALL				
	OPERATING RANGE	NOMINAL	SPEED rpm	CURRENT A	SPEED rpm	CURRENT A	TORQUE g-cm	TORQUE mN-m	OUTPUT W	EFF %	CURRENT A	TORQUE g-cm	TORQUE mN-m
BL2430B-9V6.2K3W-C1Y0P	9.0-16.0	9.0V CONSTANT	6150	0.12	4990	0.48	52.6	5.20	2.70	64	2.0	280	27.5
BL2430B-32V13.5K8W-B1X0N	9.0-34.0	32.0V CONSTANT	13500	0.10	10930	0.60	123.0	12.10	13.80	72	2.8	660	67.4

馬達的出軸長度及性能參數，EMC 對策可依客人要求做調整，詳情可詢問相關業務人員。
Please inquire your sales representative for output, performance and EMC solution.

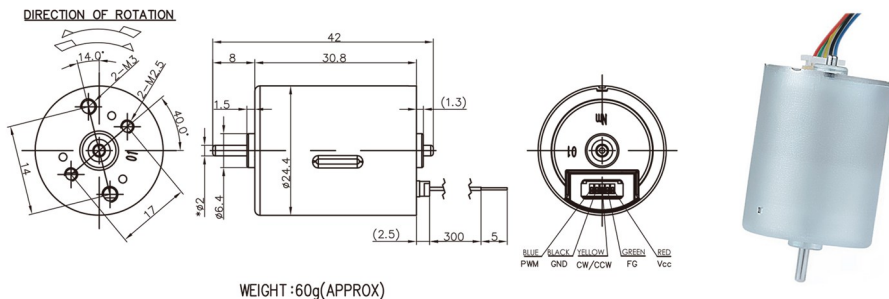

WEIGHT: 60g (APPROX)

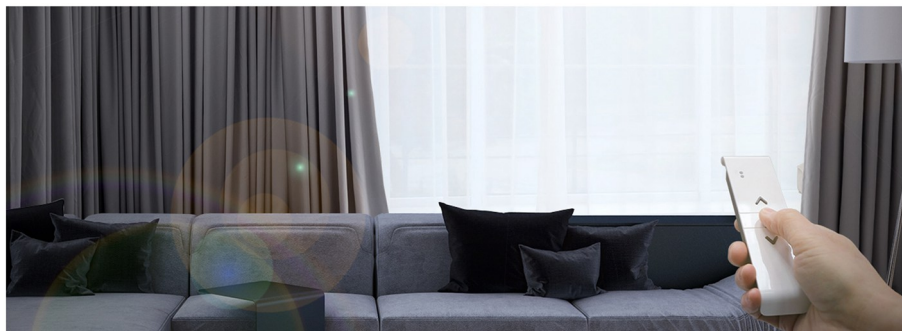
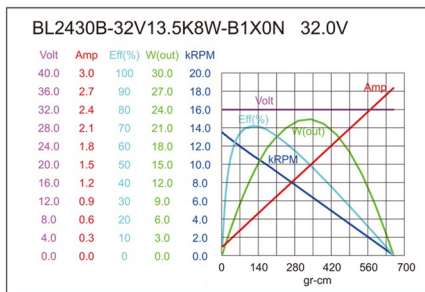
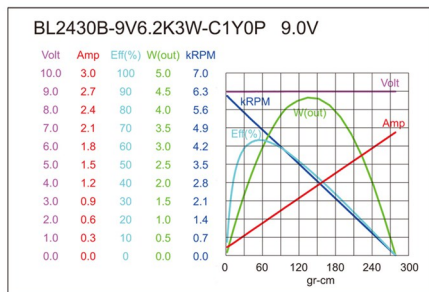

X-TEAM BL2832 无刷电机

应用范围： 电动吸尘器

MODEL	VOLTAGE		NO LOAD		AT MAXIMUM EFFICIENCY					STALL			
	OPERATING RANGE	NOMINAL	SPEED rpm	CURRENT A	SPEED rpm	CURRENT A	TORQUE g-cm	OUTPUT mN-m	EFF %	CURRENT A	TORQUE g-cm	TORQUE mN-m	
BL2832B-12V3.5K1.4W-B0X0N	6.0-30.0	12.0V CONSTANT	3500	0.67	2719	0.28	53.11	5.21	1.48	55	0.86	233.20	22.86
BL2832B-12V17.7K6.5W-C1Y1P	6.0-30.0	12.0V CONSTANT	17700	0.17	14144	0.85	46.87	4.60	6.81	73	4.23	281.64	27.61

馬達的出軸長度及性能參數，EMC 對策可依客人要求做調整，詳情可詢問相關業務人員。
Please inquire your sales representative for output, performance and EMC solution.

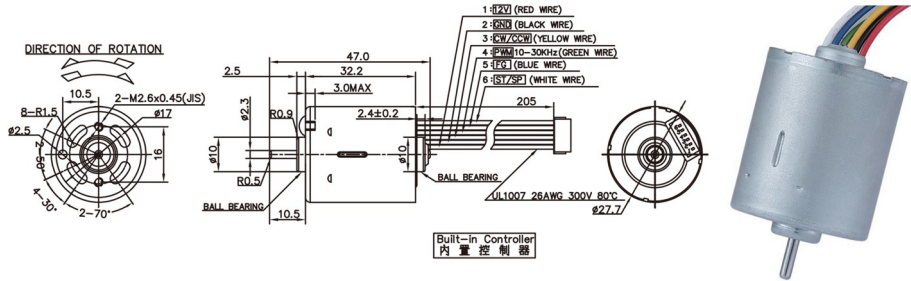

WEIGHT : 90g(APPROX)

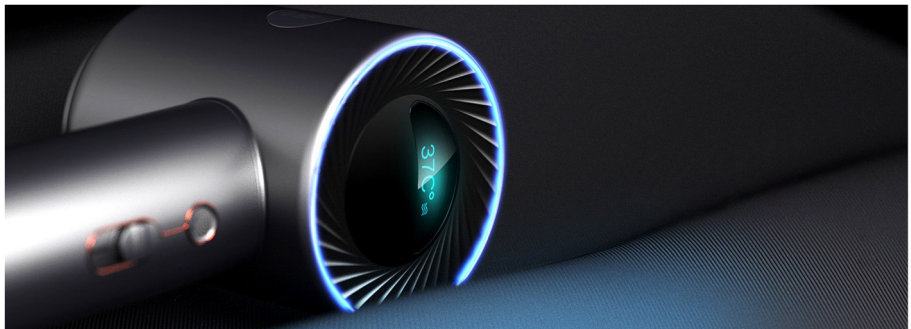
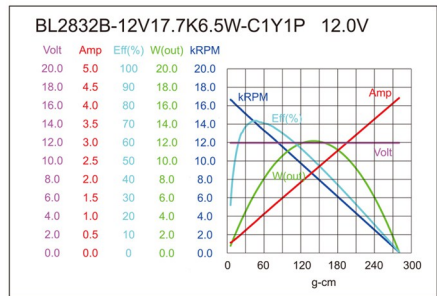
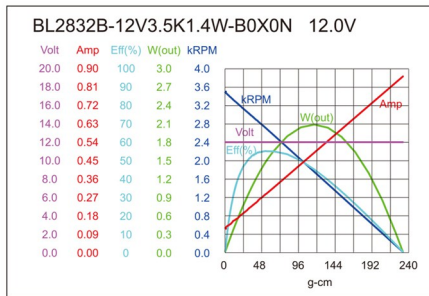

ELECTRIC TOOLS BRUSHLESS MOTOR

X-TEAM电动工具系列无刷电机

X-TEAM BL2838无刷电机

应用范围： 电动吸尘器

MODEL	VOLTAGE		NO LOAD		AT MAXIMUM EFFICIENCY					STALL			
	OPERATING RANGE	NOMINAL	SPEED rpm	CURRENT A	SPEED rpm	CURRENT A	TORQUE g-cm	TORQUE mN-m	OUTPUT W	EFF %	CURRENT A	TORQUE g-cm	TORQUE mN-m
BL2838B-12V2.9K1.4W-B0X0N	9.0-30.0	12.0V CONSTANT	2900	0.67	2248	0.28	62.55	6.13	1.44	55	0.82	267.59	26.23
BL2838B-12V12.7K15W-B1X0N	9.0-30.0	12.0V CONSTANT	12700	0.31	10730	1.79	140.30	13.75	15.46	76	8.61	803.31	78.76
BL2838B-24V6.0K4W-C1Y1P	9.0-30.0	24.0V CONSTANT	6000	0.05	5139	0.28	82.83	8.12	4.37	70	1.45	541.46	53.08
BL2838B-12V10K10W-C1Y1P	9.0-30.0	12.0V CONSTANT	10380	0.21	8834	1.21	117.20	11.49	10.63	75	6.63	810.00	79.41

馬達的出轉長度及性能參數，EMC 對策可依客人要求做調整，詳情可詢問相關業務人員。
Please inquire your sales representative for output, performance and EMC solution.

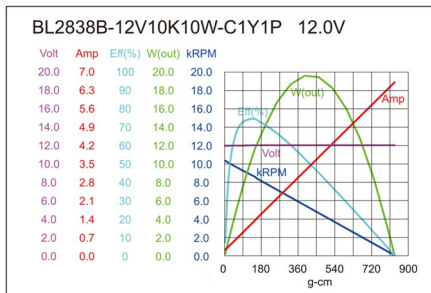
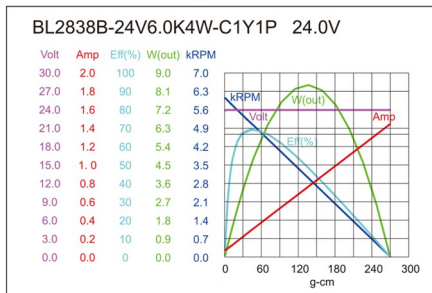
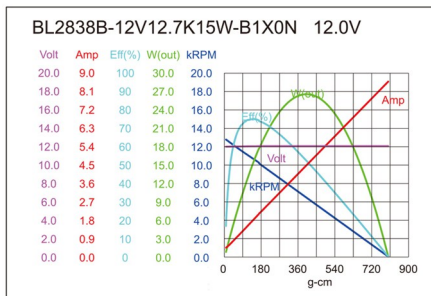
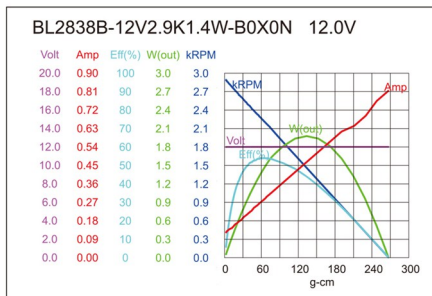
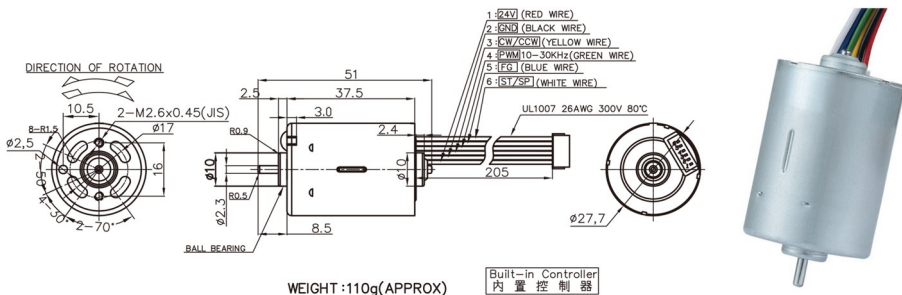

X-TEAM BL2838S 无刷电机

应用范围： 电动吸尘器

MODEL	VOLTAGE		NO LOAD		AT MAXIMUM EFFICIENCY					STALL			
	OPERATING RANGE	NOMINAL	SPEED rpm	CURRENT A	SPEED rpm	CURRENT A	TORQUE g-cm	OUTPUT mN-m	EFF %	CURRENT A	TORQUE g-cm		
BL2838S-7V35K35W-B1X0N	7.0-24.0	7.0V CONSTANT	35842	1.40	29586	7.78	126.1	12.36	38.31	71	43.62	867.15	84.98
BL2838S-24V30K50W-B1X0N	7.0-24.0	24.0V CONSTANT	30200	0.28	25613	2.90	211.4	20.72	55.61	84	18.57	1552.6	152.15

馬達的出軸長度及性能參數，EMC 對策可依客人要求做調整，詳情可詢問相關業務人員。
Please inquire your sales representative for output, performance and EMC solution.

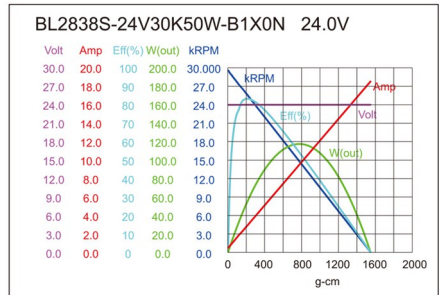
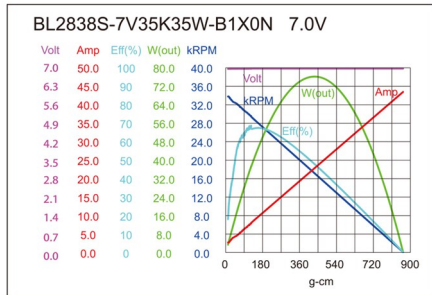
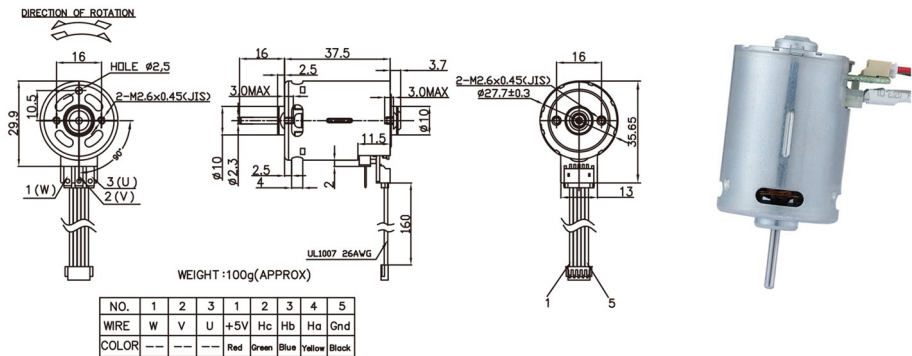

X-TEAM BL3229 无刷电机

应用范围： 自动喂食器、吹风机

MODEL	VOLTAGE		NO LOAD		AT MAXIMUM EFFICIENCY						STALL		
	OPERATING RANGE	NOMINAL	SPEED	CURRENT	SPEED	CURRENT	TORQUE	OUTPUT	EFF	CURRENT	TORQUE		
			rpm	A	rpm	A	g·cm	mN·m	W	%	A	g·cm	mN·m
BL3229B-24V6.0K4.0W-B0X0N	9.0-30.0	24.0V CONSTANT	6000	0.72	4864	0.39	90.42	8.86	4.52	65	1.45	499.32	48.95
BL3229B-12V4.0K2.5W-C1Y1P	9.0-30.0	12.0V CONSTANT	4000	0.70	3053	0.36	89.96	8.82	2.82	66	1.42	409.56	40.15
BL3229B-24V4.0K2.0W-B1X0N	9.0-30.0	24.0V CONSTANT	4000	0.05	3126	0.17	66.04	6.04	2.12	56	0.56	290.30	28.46
BL3229B-12V10.0K9W-C1Y1P	9.0-30.0	12.0V CONSTANT	10200	0.18	9107	1.03	98.17	9.62	9.18	76	8.14	916.81	89.88

馬達的輸出長度及性能參數，EMC 對策可依客人要求做調整，詳情可詢問相關業務人員。
Please inquire your sales representative for output, performance and EMC solution.

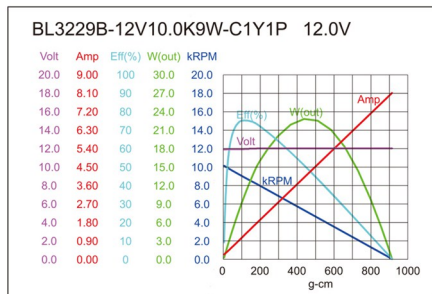
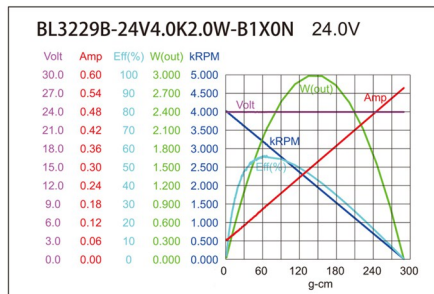
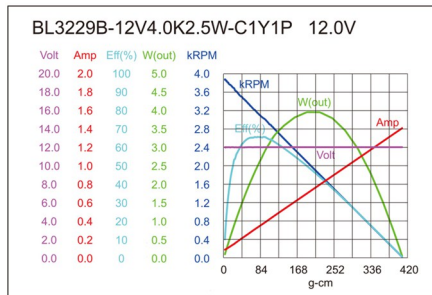
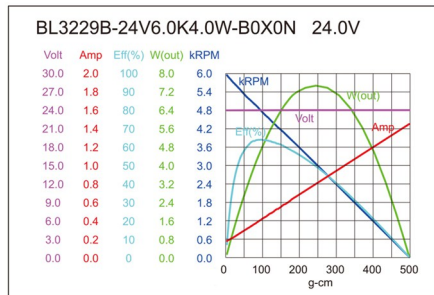
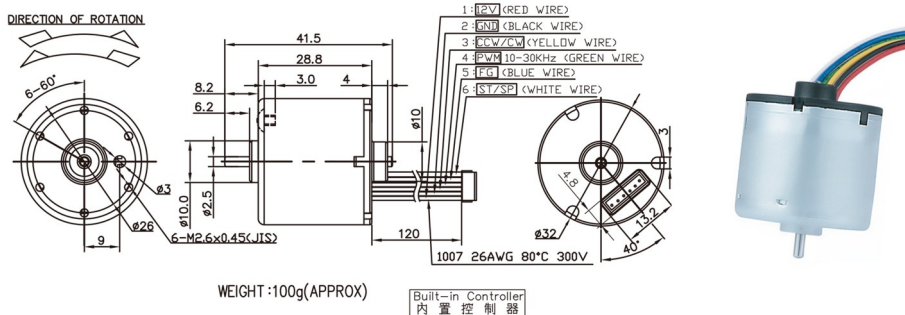

X-TEAM BL3640 无刷电机

应用范围： 齿轮箱、泵浦、机器人

MODEL	VOLTAGE		NO LOAD		AT MAXIMUM EFFICIENCY					STALL			
	OPERATING RANGE	NOMINAL	SPEED rpm	CURRENT A	SPEED rpm	CURRENT A	TORQUE g-cm	TORQUE mN-m	OUTPUT W	EFF %	CURRENT A	TORQUE g-cm	TORQUE mN-m
BL3640B-12V8.0K14W-B1X0N	10.0-30.0	12.0V CONSTANT	8000	0.42	6596	2.05	212	20.78	14.36	62	9.69	1287	126.18
BL3640B-24V9.0K23W-C1Y1P	10.0-30.0	24.0V CONSTANT	9000	0.17	7675	1.38	295	28.92	23.25	74	7.37	1859	182.25

馬達的輸出長度及性能參數，EMC 對策可依客人要求做調整，詳情可詢問相關業務人員。
Please inquire your sales representative for output, performance and EMC solution.

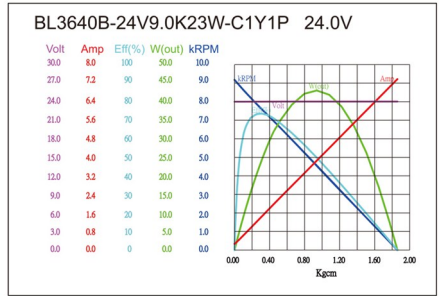
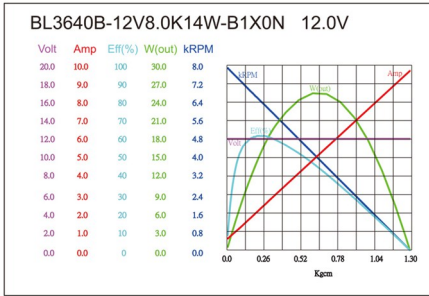
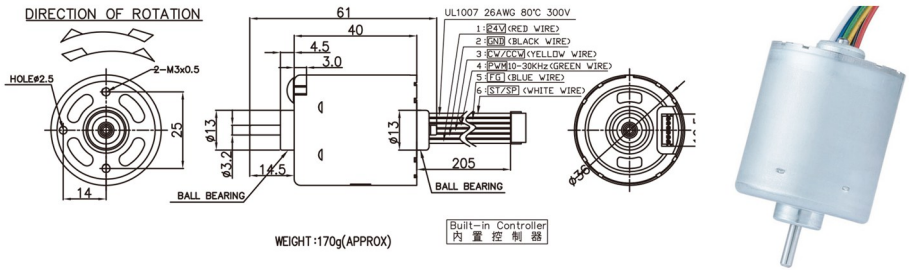

ELECTRIC TOOLS BRUSHLESS MOTOR

X-TEAM 电动工具系列无刷电机

X-TEAM BL3649 无刷电机

应用范围： 齿轮箱、泵浦、机器人

MODEL	VOLTAGE		NO LOAD		AT MAXIMUM EFFICIENCY					STALL			
	OPERATING RANGE	NOMINAL	SPEED rpm	CURRENT A	SPEED rpm	CURRENT A	TORQUE g-cm	OUTPUT mN-m	EFF %	CURRENT A	TORQUE g-cm	TORQUE mN-m	
BL3649B-24V5.0K13W-B1X0N	10.0-30.0	24.0V CONSTANT	5000	0.16	4484	0.72	286	28.04	13.17	81	5.23	2379	233.24
BL3649B-12V3.5K7.0W-C1Y1P	10.0-30.0	12.0V CONSTANT	3500	0.16	3135	0.85	242	23.73	7.79	78	6.04	1936	189.80

馬達的出軸長度及性能參數，EMC 對策可依客人要求做調整，詳情可詢問相關業務人員。
Please inquire your sales representative for output, performance and EMC solution.

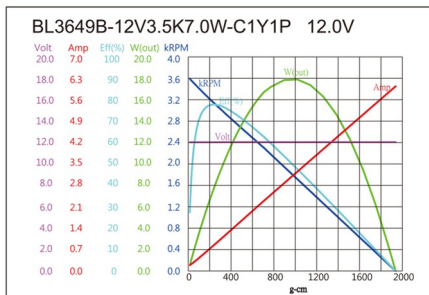
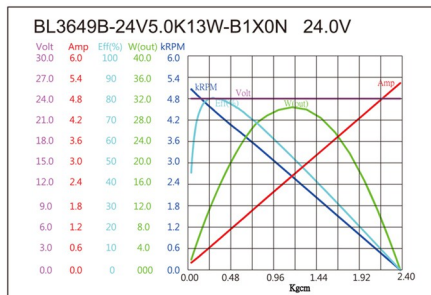
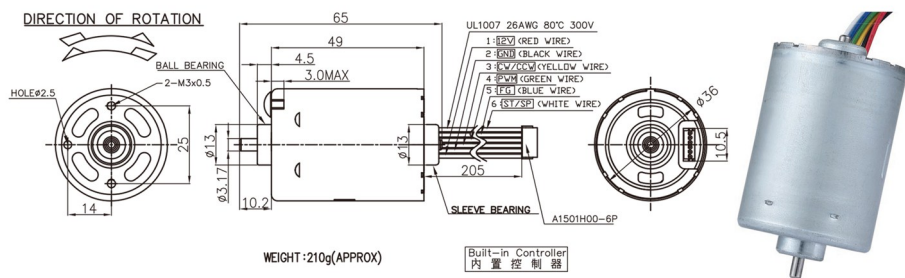

X-TEAM BL3657 无刷电机

应用范围： 齿轮箱、泵浦、风扇、汽泡布制造机

MODEL	VOLTAGE		NO LOAD		AT MAXIMUM EFFICIENCY					STALL			
	OPERATING RANGE	NOMINAL	SPEED rpm	CURRENT A	SPEED rpm	CURRENT A	TORQUE g-cm	TORQUE mN-m	OUTPUT W	EFF %	CURRENT A	TORQUE g-cm	TORQUE mN-m
BL3657B-12V2.7K5.0W-B1X0N	10.0-30.0	12.0V CONSTANT	2700	0.15	2408	0.65	217.6	21.33	5.38	74	4.05	1662.2	162.96
BL3657B-24V9.0K35W-C1Y1P	10.0-30.0	24.0V CONSTANT	9000	0.35	7786	2.16	458.9	44.99	36.69	76	11.78	2952.1	289.42

馬達的出軸長度及性能參數，EMC 對策可依客人要求做調整，詳情可詢問相關業務人員。
Please inquire your sales representative for output, performance and EMC solution.

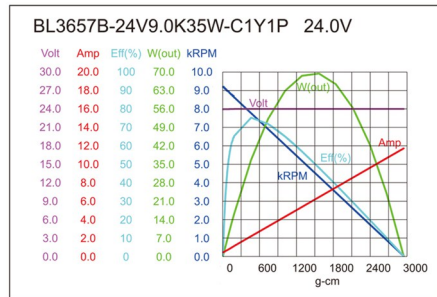
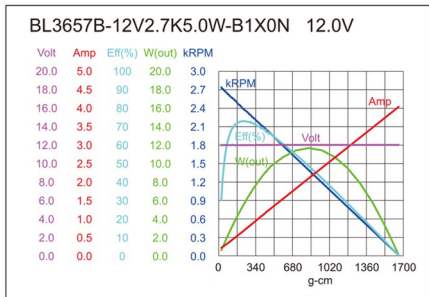
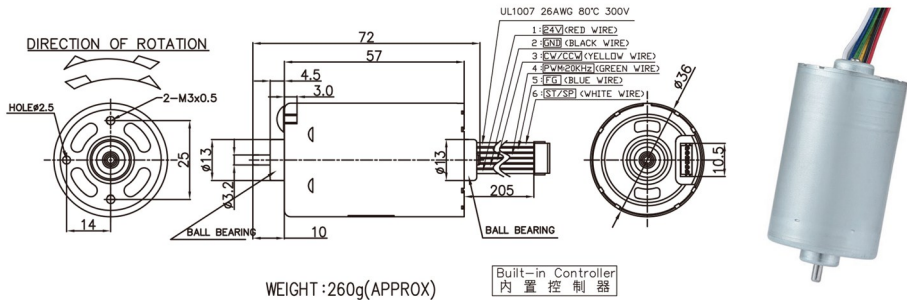

ELECTRIC TOOLS BRUSHLESS MOTOR

X-TEAM电动工具系列无刷电机

X-TEAM BL3657S无刷电机

应用范围： 电动吸尘器、呼吸机

MODEL	VOLTAGE		NO LOAD		AT MAXIMUM EFFICIENCY					STALL			
	OPERATING RANGE	NOMINAL	SPEED rpm	CURRENT A	SPEED rpm	CURRENT A	TORQUE Kg-cm	TORQUE N-m	OUTPUT W	EFF %	CURRENT A	TORQUE Kg-cm	TORQUE N-m
BL3657S-14.4V26.8K140W-B1X0N	12.0-36.0	14.0V CONSTANT	26400	1.26	22321	12.45	0.63	0.06	144.18	84	73.03	4.04	0.40
BL3657S-18V43K190W-B1X0N	12.0-36.0	18.0V CONSTANT	42300	2.00	37037	14.13	0.52	0.05	197.78	78	93.06	4.10	0.40
BL3657S-24V15K60W-B1X0N	12.0-36.0	24.0V CONSTANT	15000	0.24	13423	2.89	0.41	0.04	56.24	83	23.32	3.53	0.35
BL3657S-36V19K100W-B1X0N	12.0-36.0	36.0V CONSTANT	19300	0.30	17391	3.01	0.54	0.05	96.26	90	24.25	4.88	0.48

馬達的出軸長度及性能參數，EMC 對策可依客人要求做調整，詳情可詢問相關業務人員。
Please inquire your sales representative for output, performance and EMC solution.

DIRECTION OF ROTATION

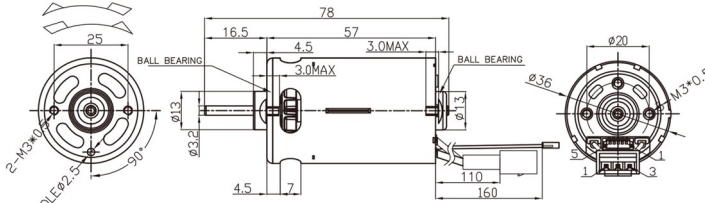

WEIGHT: 260g (APPROX)

ND.	1	2	3	1	2	3	4	5
WIRE	U	V	W	+5V	Hc	Hb	Ha	Gnd
COLOR	Grey	Brown	White	Red	Green	Blue	Yellow	Black
Type	UL3135	18AWG		UL1007	26AWG			

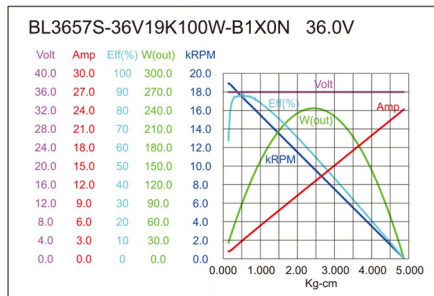
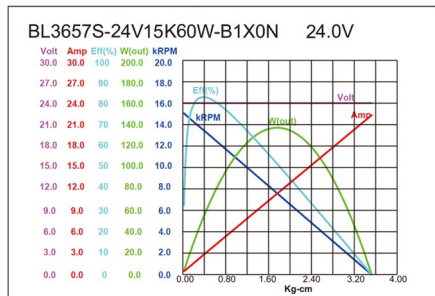
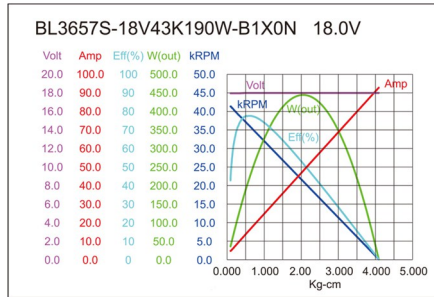
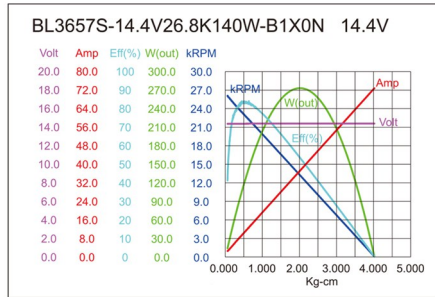

X-TEAM BL4259 无刷电机

应用范围： 水泵

MODEL	VOLTAGE		NO LOAD		AT MAXIMUM EFFICIENCY					STALL			
	OPERATING RANGE	NOMINAL	SPEED rpm	CURRENT A	SPEED rpm	CURRENT A	TORQUE g-cm	OUTPUT mN-m	EFF %	CURRENT A	TORQUE g-cm		
BL4259B-24V6.0K30W-B1X0N	10.0-26.0	24.0V CONSTANT	6100	0.25	5211	2.45	802	78.63	42.92	76	15.28	5783	566.96
BL4259B-18V4.0K20W-C1Y1P	10.0-26.0	18.0V CONSTANT	4000	0.19	3413	1.16	627	61.47	21.97	82	7.67	4786	469.22

馬達的輸出長度及性能參數，EMC 對策可依客人要求做調整，詳情可詢問相關業務人員。
Please inquire your sales representative for output, performance and EMC solution.

DIRECTION OF ROTATION

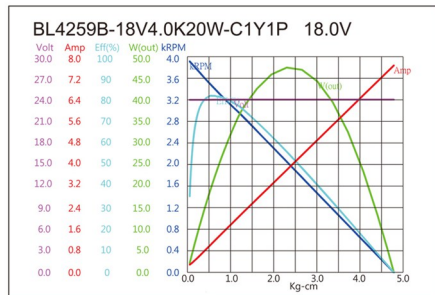
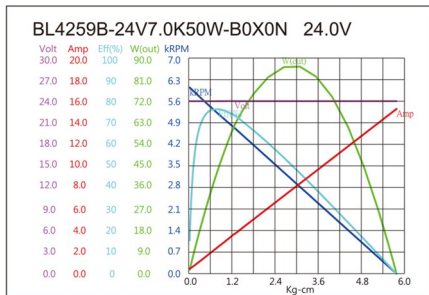
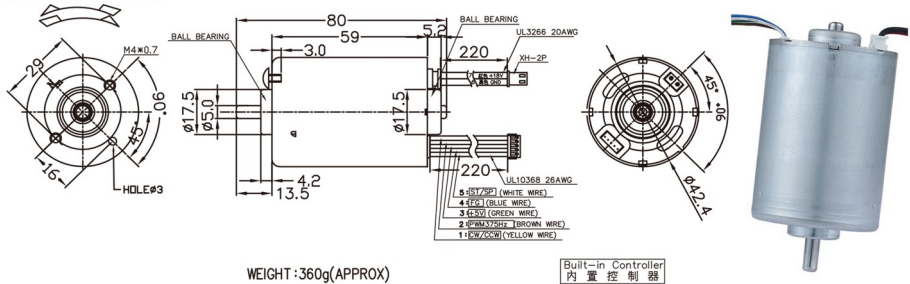

ELECTRIC TOOLS BRUSHLESS MOTOR

X-TEAM电动工具系列无刷电机

X-TEAM BL4266无刷电机

应用范围： 水泵、智能割草机

MODEL	VOLTAGE		NO LOAD		AT MAXIMUM EFFICIENCY					STALL			
	OPERATING RANGE	NOMINAL	SPEED	CURRENT	SPEED	CURRENT	TORQUE	OUTPUT	EFF	CURRENT	TORQUE		
			rpm	A	rpm	A	g-cm	mN-m	W	%	A	g-cm	mN-m
BL4266B-18V4.2K30W-B0X0N	10.0-26.0	18.0V CONSTANT	4300	0.31	3648	3.03	1128	110.59	42.26	86	18.08	7727	757.55
BL4266B-24V5.3K35W-C1Y1V	10.0-26.0	24.0V CONSTANT	5200	0.39	4570	2.11	747	73.24	35.06	76	13.42	6115	559.51

馬達的出軸長度及性能參數，EMC 對策可依客人要求做調整，詳情可詢問相關業務人員。
Please inquire your sales representative for output, performance and EMC solution.

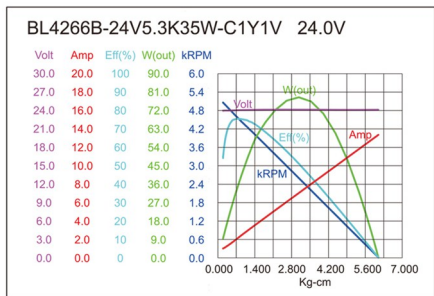
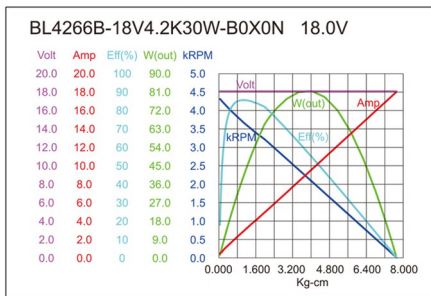
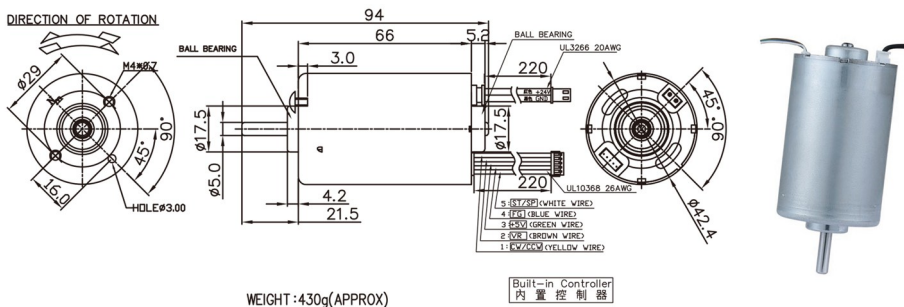

X-TEAM BL4244 无刷电机

应用范围： 电动工具

MODEL	VOLTAGE		NO LOAD		AT MAXIMUM EFFICIENCY					STALL			
	OPERATING RANGE	NOMINAL	SPEED rpm	CURRENT A	SPEED rpm	CURRENT A	TORQUE g-cm	TORQUE mN-m	OUTPUT W	EFF %	CURRENT A	TORQUE g-cm	TORQUE mN-m
BL4244S-18V21K160W-B1X0N	12.0-24.0	18.0V CONSTANT	20500	1.74	17986	12.55	906	88.82	167.35	80	95.54	7645	749.51
BL4244S-18V26K230W-B1X0N	12.0-24.0	18.0V CONSTANT	26200	3.30	22371	18.75	1208	118.43	236.17	75	117.33	7570	742.16

馬達的輸出長度及性能參數，EMC 對策可依客人要求做調整，詳情可詢問相關業務人員。
Please inquire your sales representative for output, performance and EMC solution.

DIRECTION OF ROTATION

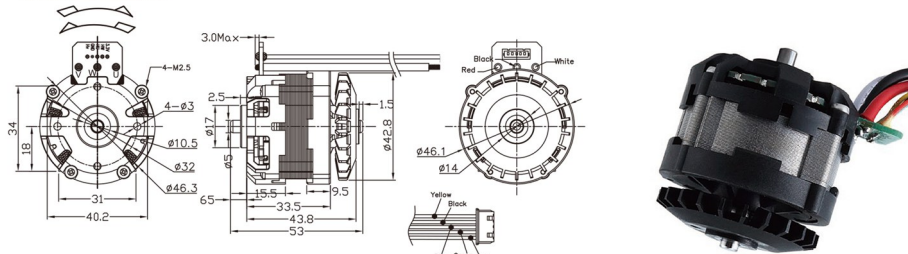

WEIGHT: 200g (APPROX)

definition of the wire	wire from the motor			wire from the hall			
	U	V	W	+5V GND	HU	HV	HW
color of the wire	Red	White	Black	Red	Black	Blue	Yellow/Green

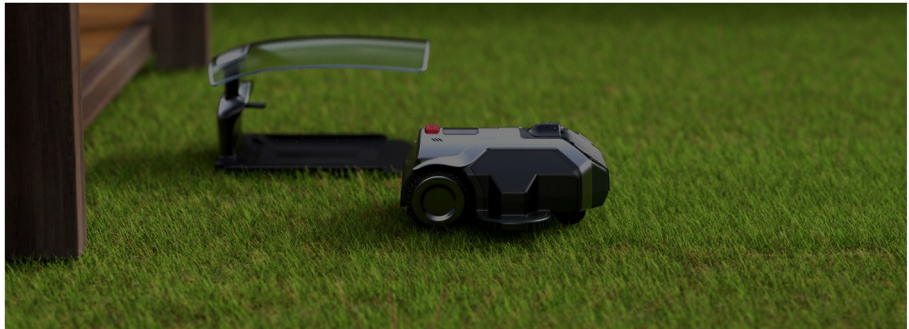
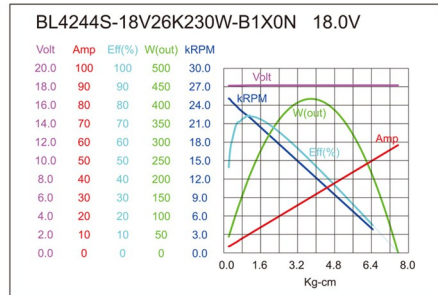
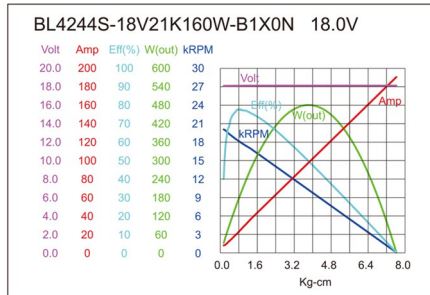

ELECTRIC TOOLS BRUSHLESS MOTOR

X-TEAM电动工具系列无刷电机

X-TEAM BL7084无刷电机

应用范围：电锯

MODEL	VOLTAGE		NO LOAD		AT MAXIMUM EFFICIENCY					STALL			
	OPERATING RANGE	NOMINAL	SPEED	CURRENT	SPEED	CURRENT	TORQUE	OUTPUT	EFF	CURRENT	TORQUE		
			rpm	A	rpm	A	g-cm	mN-m	W	%	A	g-cm	mN-m
BL7084S-12V5.8K120W-BOXON	12.0-48.0	12.0V CONSTANT	5800	1.65	4909	13.70	2507	245.78	126.38	83	106.82	22031	2159.90
BL7084S-40V16.4K1000W-B1XON	12.0-48.0	40.0V CONSTANT	16400	3.20	13158	32.58	7632	748.24	1031.29	82	154.62	40101	3931.41

馬達的出軸長度及性能參數，EMC 對策可依客人要求做調整，詳情可詢問相關業務人員。
Please inquire your sales representative for output, performance and EMC solution.

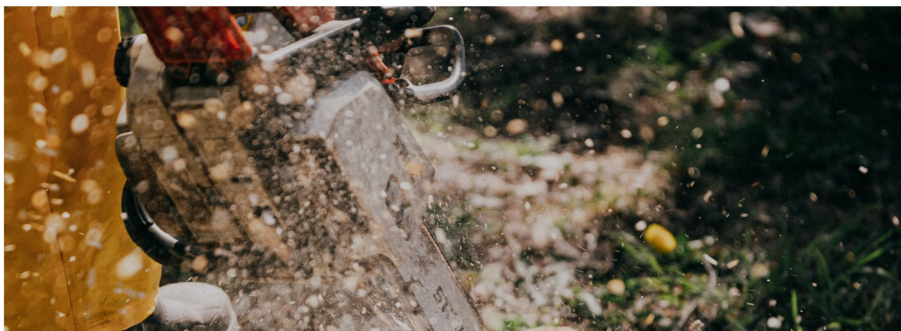
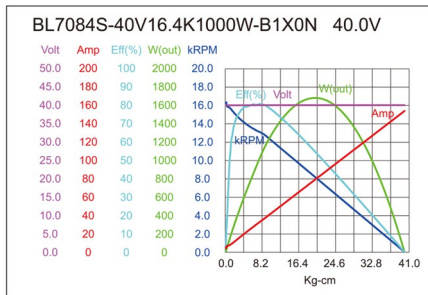
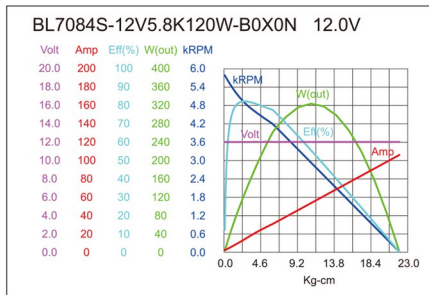
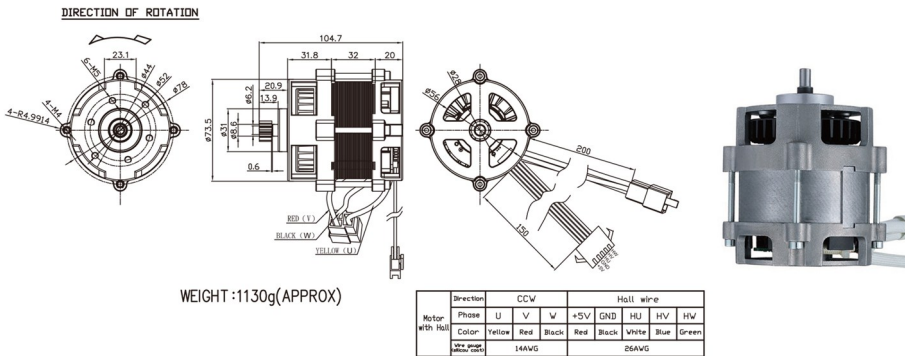

X-TEAM BL4016 无刷电机

应用范围： 吹风机

Motor Performance (Without Fan) / 電機性能 (無風葉)

MODEL	VOLTAGE		NO LOAD		AT MAXIMUM EFFICIENCY				STALL				
	OPERATION RANGE	NOMINAL	SPEED	CURRENT	SPEED	CURRENT	TORQUE	OUTPUT	EFF.	CURRENT	TORQUE		
			rpm	A	rpm	A	g-cm	mN-m	W	%	A	g-cm	mN-m
BL40E16B-220V19K80W-C1Y0V	(176-240)Vac	220Vac/60HZ	19000	0.12	14800	0.5	260	25.5	40	64	1.7	1186	116.3
BL40E16B-120V18K110W-C1Y0P	(96-144)Vac	120Vac/60HZ	18000	0.24	10760	0.8	360	35.3	40	63	2.0	1260	123.5

馬達的出軸長度及性能參數，EMC 對策可依客人要求做調整，詳情可詢問相關業務人員。
Please inquire your sales representative for output, performance and EMC solution.

Motor Performance (With Fan) / 電機性能 (帶風葉)

MODEL	VOLTAGE		NO LOAD		ON LOAD (IN DRYER HOUSING)				CONTROLLER FUNCTION
	OPERATION RANGE	NOMINAL	SPEED	CURRENT	IMPELLER SPEED	INPUT CURRENT	INPUT POWER	AIR VELOCITY	
			rpm	A	rpm	A	w	m/s	
BL40E16B-220V19K80W-C1Y0V	(176-240)Vac	220Vac/60HZ	19000	0.12	8800	0.7	105	18.5	1.VOLTAGE SPEED ADJUSTMENT 2.PWM SPEED ADJUSTMENT 3.LOCKED ROTOR PROTECTION 4.OVER CURRENT PROTECTION 5.OVER VOLTAGE PROTECTION 6.OVER TEMPERATURE PROTECTION 7.FG PROTECTION
BL40E16B-120V18K110W-C1Y0P	(96-144)Vac	120Vac/60HZ	18000	0.24	8400	1.1	100	18.5	

馬達的出軸長度及性能參數，EMC 對策可依客人要求做調整，詳情可詢問相關業務人員。
Please inquire your sales representative for output, performance and EMC solution.

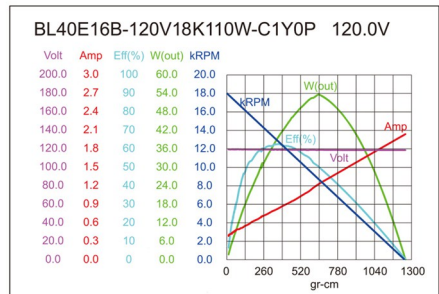
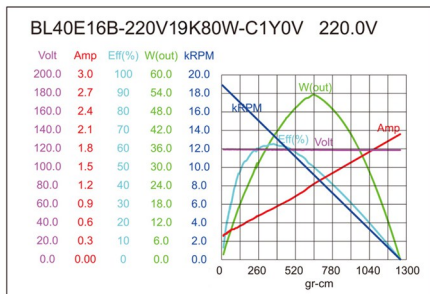
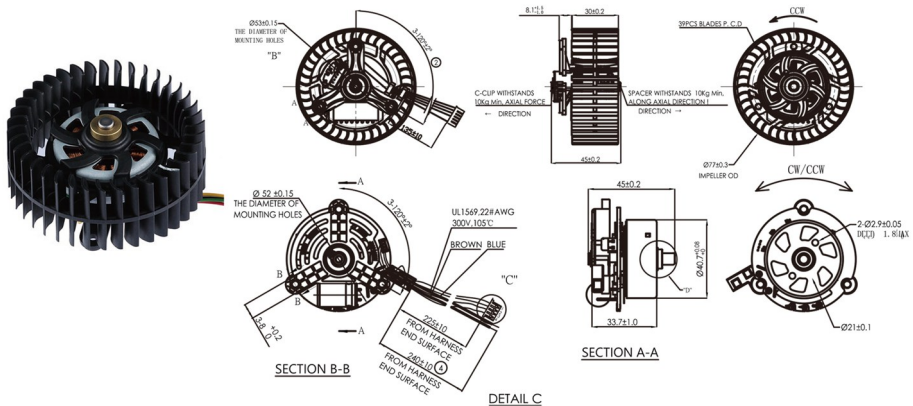

ELECTRIC TOOLS BRUSHLESS MOTOR

X-TEAM电动工具系列无刷电机

X-TEAM BL4815无刷电机

应用范围： 电动工具

MODEL	VOLTAGE		NO LOAD		AT MAXIMUM EFFICIENCY					STALL			
	OPERATING RANGE	NOMINAL	SPEED rpm	CURRENT A	SPEED rpm	CURRENT A	TORQUE Kg-cm	TORQUE N-m	OUTPUT W	EFF %	CURRENT A	TORQUE Kg-cm	TORQUE N-m
BL48F15S-18V16K180W-B1X0N	14.4-21.6V	18.0V CONSTANT	16150	2.13	13966	14.37	1.28	0.13	183.73	78	92.37	9.38	0.92
BL48F15S-21.6V21K240W-B1X0N	14.4-21.6V	21.6V CONSTANT	20500	2.40	18051	15.42	1.30	0.13	240.99	73	98.59	8.73	0.86

馬達的出軸長度及性能參數，EMC 對策可依客人要求做調整，詳情可詢問相關業務人員。
Please inquire your sales representative for output, performance and EMC solution.

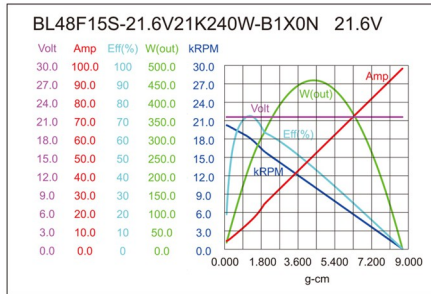
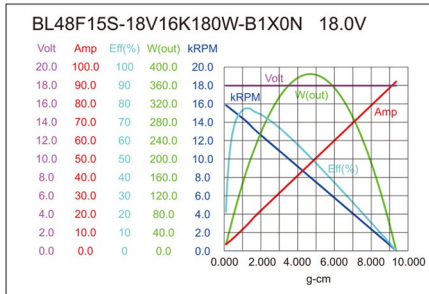
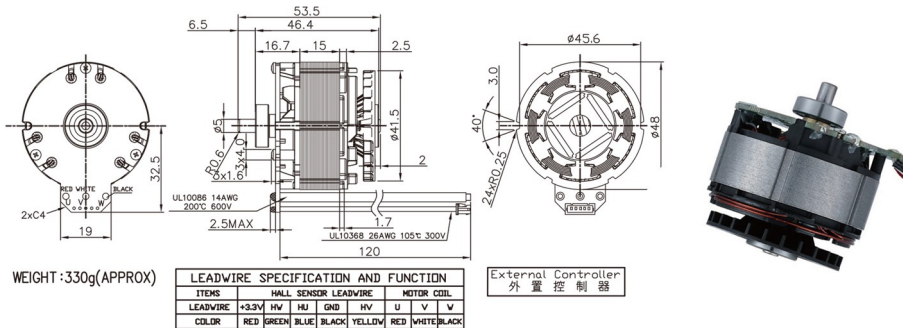

X-TEAM BL4823 无刷电机

应用范围： 电动工具

MODEL	VOLTAGE		NO LOAD		AT MAXIMUM EFFICIENCY				STALL				
	OPERATING RANGE	NOMINAL	SPEED rpm	CURRENT A	SPEED rpm	CURRENT A	TORQUE Kg-cm	OUTPUT W	EFF %	CURRENT A	TORQUE Kg-cm		
BL48F23S-14.4V24K400W-B1XON	14.4-21.6V	14.4V CONSTANT	24000	7.80	20243	41.37	2.01	0.20	417.44	72	218.85	12.91	1.27
BL48F23S-18V23K450W-B1XON	14.4-21.6V	18.0V CONSTANT	23000	4.70	20450	33.50	2.16	0.21	453.84	76	210.75	15.75	1.54

馬達的輸出長度及性能參數，EMC 對策可依客人要求做調整，詳情可詢問相關業務人員。
Please inquire your sales representative for output, performance and EMC solution.

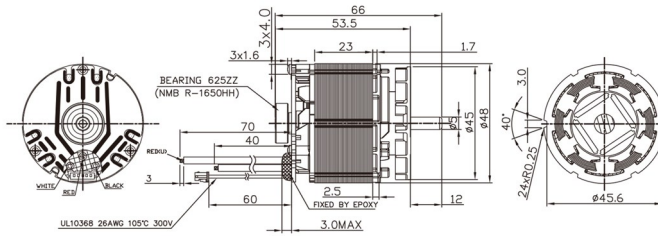

LEADWIRE SPECIFICATION AND FUNCTION							
ITEMS	HALL	SENSOR	LEADWIRE	MOTOR COIL			
LEADWIRE	+3.3V	HV	HJ	GND	HV	U	V
COLOR	RED	GREEN	BLUE	BLACK	YELLOW	RED	WHITE/BLACK

WEIGHT :330g(APPROX)

External Controller
外置控制器

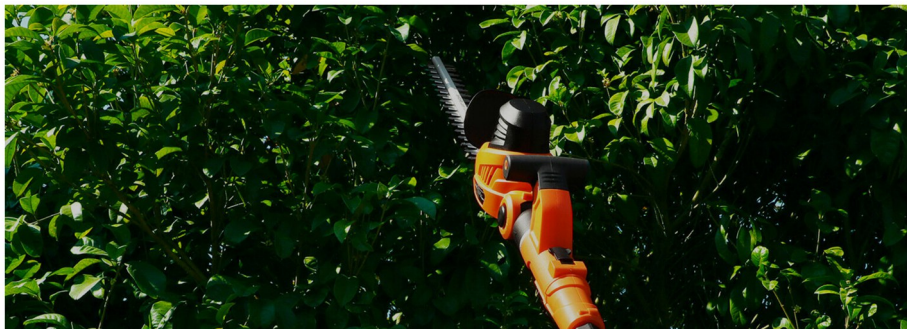
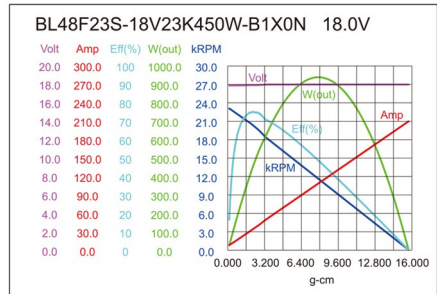
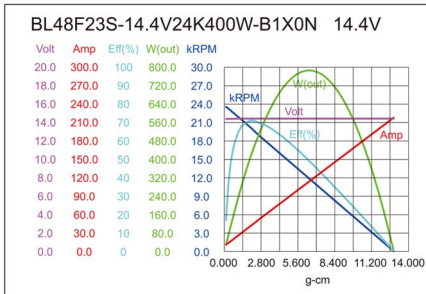
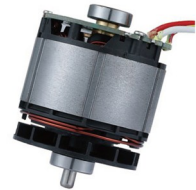

ELECTRIC TOOLS BRUSHLESS MOTOR

X-TEAM 电动工具系列无刷电机

X-TEAM BL4825 无刷电机

应用范围： 电动工具

MODEL	VOLTAGE		NO LOAD		AT MAXIMUM EFFICIENCY					STALL			
	OPERATING RANGE	NOMINAL	SPEED	CURRENT	SPEED	CURRENT	TORQUE	OUTPUT	EFF	CURRENT	TORQUE		
			rpm	A	rpm	A	Kg-cm	N-m	W	%	A	Kg-cm	N-m
BL48F25S-18V24K500W-B1X0N	14.4-21.6V	18.0V CONSTANT	24000	6.40	20747	38.34	2.39	0.23	510.07	76	228.74	16.60	1.63
BL48F25S-21.6V23.5K370W-B1X0N	14.4-21.6V	21.6V CONSTANT	23500	4.60	21186	25.60	1.73	0.17	376.40	72	193.89	15.70	1.54

馬達的輸出長度及性能參數，EMC 對策可依客人要求做調整，詳情可詢問相關業務人員。
Please inquire your sales representative for output, performance and EMC solution.

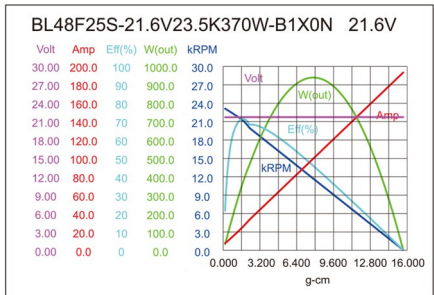
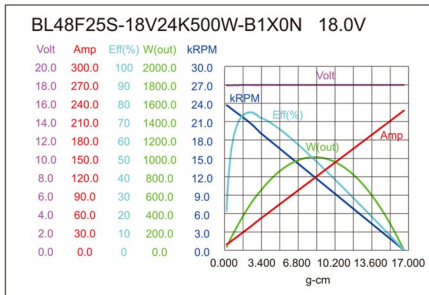
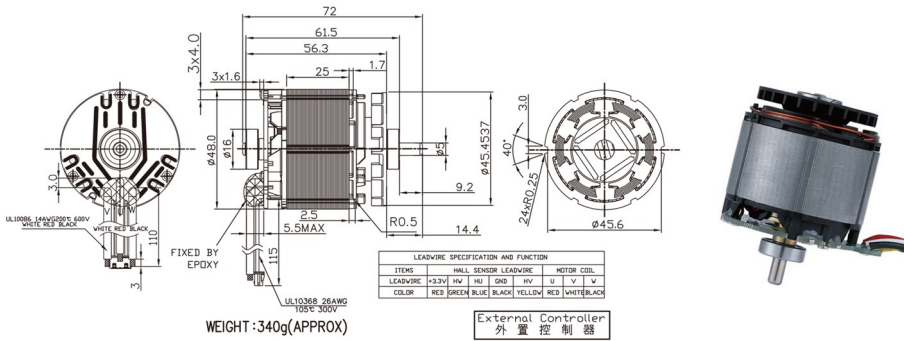

X-TEAM BL5025 无刷电机

应用范围： 电钻、电锤、冲击扳手

MODEL	VOLTAGE		NO LOAD		AT MAXIMUM EFFICIENCY					STALL			
	OPERATING RANGE	NOMINAL	SPEED rpm	CURRENT A	SPEED rpm	CURRENT A	TORQUE Kg-cm	TORQUE mN-m	OUTPUT W	EFF %	CURRENT A	TORQUE Kg-cm	TORQUE mN-m
BL50F25S-18V26K600W-B1X0N	18.0-21.6V	18.0V CONSTANT	26000	6.20	22520	48.0	3.00	294	704	82	240	18.0	176
BL50F25S-21.6V22K450W-B1X0N	18.0-21.6V	21.6V CONSTANT	22000	5.20	19120	26.6	2.20	215	446	79	182	17.5	171

馬達的輸出長度及性能參數，EMC 對策可依客人要求做調整，詳情可詢問相關業務人員。
Please inquire your sales representative for output, performance and EMC solution.

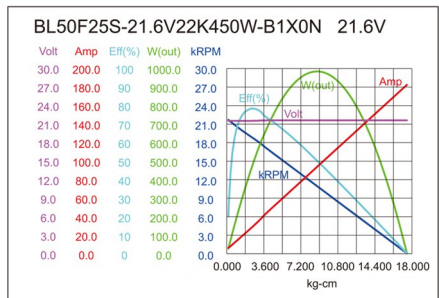
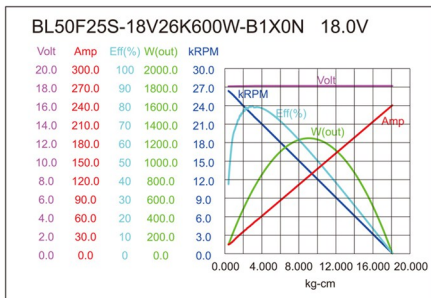
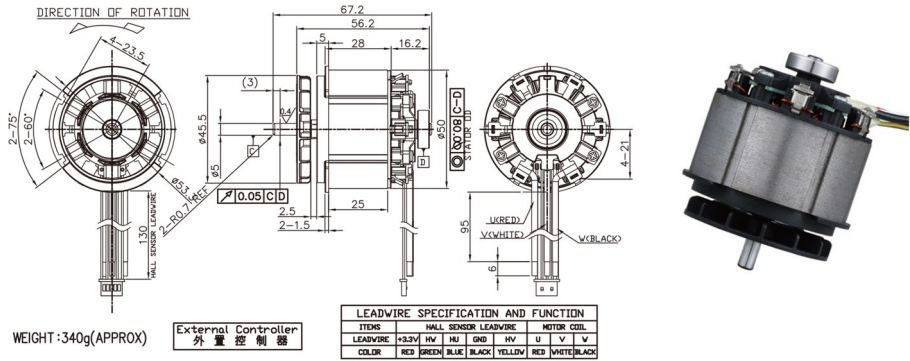

ELECTRIC TOOLS BRUSHLESS MOTOR

X-TEAM 电动工具系列无刷电机

X-TEAM BL5032 无刷电机

应用范围：电锤、电钻、角磨机、圆锯

MODEL	VOLTAGE		NO LOAD		AT MAXIMUM EFFICIENCY					STALL			
	OPERATING RANGE	NOMINAL	SPEED	CURRENT	SPEED	CURRENT	TORQUE	OUTPUT	EFF	CURRENT	TORQUE		
			rpm	A	rpm	A	Kg-cm	mN-m	W	%	A	Kg-cm	mN-m
BL50F32S-18V23K700W-B1X0N	18.0-43.2V	18.0V CONSTANT	23000	9.40	19960	54	3.6	353	742	78	260	20.9	204
BL50F32S-20V21K600W-B1X0N	18.0-43.2V	20.0V CONSTANT	21000	7.60	17330	40	3.6	353	642	84	207	21.8	213
BL50F32S-36V21K700W-B1X0N	18.0-43.2V	36.0V CONSTANT	21000	2.50	18050	24	4.0	392	740	91	150	28.3	277
BL50F32S-43.2V23K1000W-B1X0N	18.0-43.2V	43.2V CONSTANT	23000	5.10	18760	28	4.9	480	958	86	128	27.4	268

馬達的出軸長度及性能參數，EMC 對策可依客人要求做調整，詳情可詢問相關業務人員。
Please inquire your sales representative for output, performance and EMC solution.

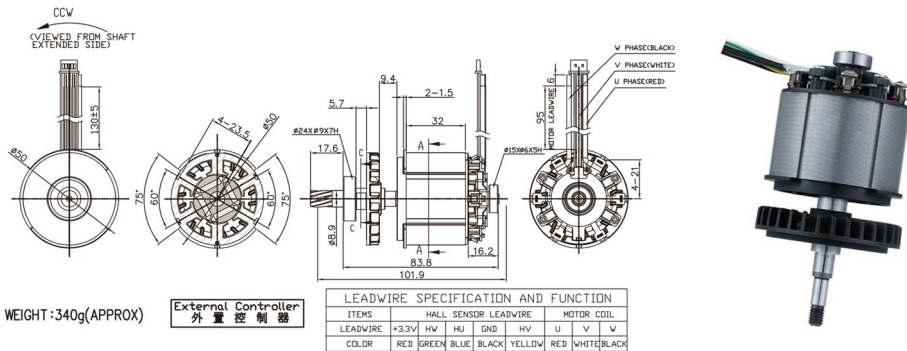

WEIGHT : 340g (APPROX)

External Controller
外置控制器

